

ISS 108 & ISS 408

INTEGRATION SEAMLESS SWITCHERS

- Seamless switching between all inputs using cuts and dissolves
- Eight fully configurable video inputs on BNCs accept anything from composite video to RGBHV
- Preview output for viewing of "next-to-switch" source
- Versatile remote control capabilities
- High performance scaling engine
- Audio cross-fading
- 32 scaled output rates including HDTV (ISS 408)
- IP Link™ Ethernet Control

Universal Seamless Switchers For System Integration



Extron® Electronics

ISS 108 & ISS 408 – Integration Seamless Switchers

True Seamless Switching for Integrated Systems

The Extron ISS Series of Integration Seamless Switchers provide seamless, glitch-free switching, as well as superior scaling with proprietary Extron technologies including 3:2 and 2:2



The ISS Series offers seamless switching for world-class boardrooms

pull-down, Dynamic Motion Interpolation (DMI™), and patented Accurate Frame Lock (AFL™). With features such as 16 auto-memories per input, test patterns for projector setup, preview capability, and audio cross-fade, the ISS Series

is a superb solution for professional A/V applications that incorporate large screen projectors and displays. This includes world-class boardrooms, high-end conference rooms, classrooms, churches, auditoriums, or other “live” environments where professional-grade transitions between A/V sources are essential.

There are two integration seamless switchers in this series: the ISS 108 and the ISS 408. Both offer comparable features including eight inputs configurable for RGBHV, RGBS, RGsB, component video, S-video, and/or composite video on female BNCs and two high resolution scaled RGB outputs on female BNCs and/or female 15-pin HD connectors. Stereo audio (balanced/unbalanced) is input on eight, captive screw connectors and is output (balanced/unbalanced) on two, captive screw connectors. Both seamless switchers in this series are also available with an optional output board for Digital Visual Interface (DVI).

The ISS Series is perfect for “live” environments where professional-grade transitions between A/V sources are essential



In addition to the standard video formats, the ISS 408 also accepts HDTV. The other difference between the two models is in the scaled output rates each support. The ISS 108 can scale 17 different rates up to 1024 x 768. The ISS 408 supports 32 different output rates, up to 1365 x 1024, and including 480p, 720p, 1080p, and 1080i.

Each ISS model can ease transitions with professional video cuts and full motion dissolves to ensure that presentations flow effortlessly. Optimum flexibility is achieved by the ISS Series “preview” and “program” outputs. This allows a presenter to confidently control the presentation by reviewing sources on a local “preview” monitor before switching them to the “program” output for the viewing audience. The presenter can continue watching what the audience sees on the “preview” screen until switching to another source. This is beneficial when synchronizing DVD or VCR players, starting from a specific point in a slide presentation, orchestrating camera angles, and maintaining a steady and dynamic pace throughout an entire presentation.

Housed in a rack-mountable, 3U high metal enclosure, the ISS series includes a host of control choices including RS-232 capability, IP Link™ Ethernet control, or the optional Extron RCP 2000 Remote Control Panel.

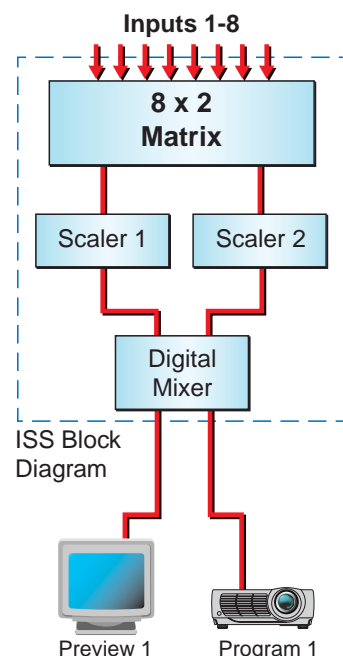

ISS 108 & ISS 408

Rugged metal enclosure
Built to withstand everyday handling in real-world environments.

Input buttons may be labeled
Input buttons can be easily labeled by any Brother® P-Touch labeler or Extron's label software with names, alphanumeric characters, or even color bitmaps for intuitive input selection.

16 auto memories per input
Auto memories save picture control settings to allow multiple computer sources to be switched into a single input.

Intuitive LCD interface
The easy-to-read LCD menu simplifies operation and control.



Input selection
Convenient and accessible front panel input selection buttons with corresponding LED lights to specify the selected input.

Picture adjustments
Brightness, contrast, centering, color, tint, detail, size, and zoom can all be adjusted through the front panel. With the zoom feature, images can be enlarged up to 200%, as well as panned. Direct access to these picture controls provides a quick and efficient set-up of the image.

Internal international power supply
Autoswitchable internal power supply provides world-wide power compatibility.

Eight configurable inputs
Accept RGBHV, RGBS, RGSB, component video, S-video, and composite video, as well as HDTV for the ISS 408, for more flexibility in system design.

Preview output
Preview of "next-to-switch" source offers opportunity for last minute adjustments, synchronization, and maintaining a steady and dynamic pace during a presentation.

Dual-buffered "Preview" and "Program" outputs
15-pin HD and BNC outputs enable a signal to be easily monitored or distributed without using a distribution amplifier.



Balanced or unbalanced audio with adjustable gain and attenuation
Allows users to adjust the gain/attenuation level from the front panel or RS-232. Individual input audio levels may be adjusted so there are no noticeable volume differences between sources.

Audio cross-fade capabilities
This transition technique enables seamless audio switching to synchronize with its video counterpart for a high quality and cohesive presentation.

Optional DVI output
Digital Visual Interface (DVI) allows for a bi-directional digital-to-digital connection, eliminating analog-to-digital (A/D) and digital-to-analog (D/A) conversion stages. This results in improved image quality and easier set-up.

RS-232 control
RS-232 utilizes Extron's exclusive Simple Instruction Set (SIS™) via third party control or Extron's Windows based control program. RS-232 is a convenient alternative to controlling basic operations and functions.

IP Link™ Ethernet control
Browser-based control via TCP/IP, the primary supported protocol (communications method) on the Internet. Existing network architecture can be used to create a flexible, scalable control solution for remote operation.

WHAT'S INSIDE the ISS Series

Technologies

Dynamic Motion Interpolation (DMI™)

Dynamic Motion Interpolation (DMI™) is Extron's proprietary de-interlacing technology that enables the ISS switchers to measure and compensate for motion artifacts, such as jaggies, that can distort an image when video is de-interlaced. The DMI process delivers the best aspects of still and motion algorithms and introduces a new level of image enhancement capability without compromising image fidelity. Utilizing DMI, the ISS switchers are able to provide superior image quality.



without DMI technology

with DMI technology

Accu-RATE Frame Lock (AFL™)

Accu-RATE Frame Lock (AFL™) is a patented technology exclusive to Extron that solves frame rate conversion issues experienced by video scalers. When video input and output refresh rates differ, there are certain points in time when the two rates cross over each other. The result is a glitch or image freeze on the display. AFL solves this problem by locking the output frame rate to the input frame rate.



Without AFL, image tearing is present in this series of images

3:2 and 2:2 Pulldown Detection

3:2 pull-down detection for NTSC and 2:2 film detection for PAL is an advanced film mode processing technique. It helps maximize image detail and sharpness for NTSC or PAL sources that originated from film. The ISS 108 and ISS 408 use pull-down and film detection to match film to video frame rates for smoother and more natural video.

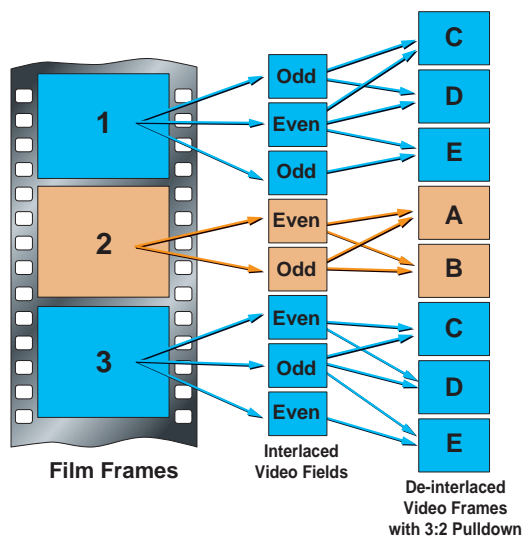

Aspect Ratio Conversion with Memories

The ISS 108 and ISS 408 feature individual horizontal and vertical image sizing controls with a wide adjustment range. By adjusting the vertical and horizontal image size controls, the scalers can easily accommodate various input signal and display device aspect ratios. In addition, the ISS 108 & ISS 408 offers three aspect ratio memory presets per input directly accessible by repeatedly pressing the input selection buttons.

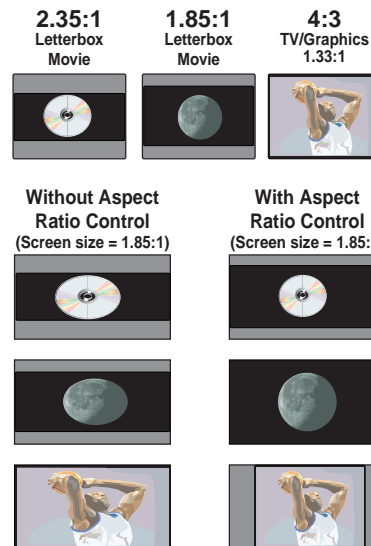

WHAT'S INSIDE the ISS Series

Features

Configurable Inputs

The ISS 108 and the ISS 408 each include eight inputs configurable for RGBHV, RGBS, RGsB, component video, S-video, and/or composite video on female BNCs and two high resolution RGB outputs on female BNCs and/or female 15-pin HD connectors. The ISS 408 also supports HDTV. Stereo audio (balanced/unbalanced) comes in via eight, captive screw connectors and is output (balanced/unbalanced) on two, captive screw connectors. Both seamless switchers in this series are also available with optional output boards for Digital Visual Interface (DVI).



Professional Transition Effects

At the heart of its seamless switching capabilities are the "cut" and "dissolve" transition effects. Dissolve rates are controlled through the front panel menu or other optional control device.

Test Patterns

The ISS Series outputs 10 different test patterns including a crop pattern, cross hatch, 16-bar grayscale, color bars, alternating on/off pixels, ramp, 4 x 4 cross hatch, and three aspect ratio patterns. Test patterns are extremely useful in checking brightness, contrast and sharpness, as well as the convergence of CRT projector and digital display devices, the proper color temperature, grayscale linearity, and bandwidth of a video signal. Ultimately, test patterns aid in preliminary picture set-up, maximizing the potential of the image while minimizing image artifacts and other noise that occurs during signal processing.

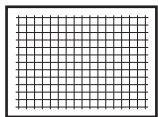

Cross Hatch



Crop



Color Bars



Grayscale

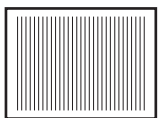

On/Off Pixel



4x4 Cross Hatch



Film Aspect Ratios



Ramp

Scaled Output Rates

Scaled output rates differ between the ISS 108 and 408. The ISS 108 can output 17 different rates up to 1024 x 768. The ISS 408 supports 32 different output rates, including these popular computer-video, plasma, and HDTV rates:

640 x 480	1024 x 768	480p
800 x 600	1280 x 768	720p
832 x 624	1280 x 1024	1080p
848 x 480	1360 x 765	1080i
852 x 480	1365 x 1024	

RS-232 Control

Using Extron's Simple Instruction Set (SIS™), RS-232 operates via third-party control or Extron's Windows®-based control program. SIS allows easy RS-232 control with simple, redefined commands that minimize the requirements for programming.



IP Link™ Ethernet Control

An IP integration technology developed by Extron specifically engineered to meet the needs of professional A/V environments that enables the ISS Series to be controlled and proactively monitored over a LAN, WAN, or the Internet. An intuitive Web interface is also included for such common functions as I/O switching, system control, and online diagnostics and monitoring.

Audio Cross-Fade

A unique feature of the ISS Series, audio cross-fade is activated when the dissolve button is pushed. This enables the switcher to simultaneously fade out one source of audio while fading up another. In this instance, the audio is perfectly synchronized with its video counterpart.

Audio Breakaway Switching

Audio breakaway is another option that allows the video and audio to be switched independently from one another. Audio breakaway is often used when the audio and video sources brought together for a presentation are not generated by the same source.

Memory Presets

The ISS switchers support 16 auto recall memories per input, based on the incoming horizontal and vertical frequencies. These memories save sizing, centering, detail, contrast, and brightness information for each source. Automatic recall of presets can save an enormous amount of time and effort in fine-tuning displayed images.

Auto-Image™ Setup

A press of a button automatically adjusts the sizing, centering, and filtering to optimize the scaled output image. This can save time and effort in fine-tuning displayed images.

OPTIONS for the ISS Series

DVI Board

Both seamless switchers in this series are also available with an optional output board for Digital Visual Interface (DVI). The DVI output enables the connection of a digital display device, which can double as an additional display when other outputs are connected.



RCP 2000

The Extron RCP 2000 is an optional Remote Control Panel that can be used to operate the ISS Series via an IP Link™ Ethernet connection. The RCP 2000 enables the user to select an input, change transition effects, and make adjustments to transition duration and picture control—all from a remote location. The ISS can be controlled simultaneously by the RCP 2000 and through RS-232, offering the user far more control flexibility. In addition to input, transition and picture buttons, the RCP 2000 is equipped with a T-bar for manual control of dissolve speed, as well as a gooseneck lamp for low-light environments.

ISS 108 and ISS 408 Differences

Scaled Output Rates – Both ISS models have superior scaling capabilities via Extron’s proprietary technologies. However, the ISS 408 offers a higher speed scaling engine, which enables it to support a higher number of output rates. The ISS 108 can output 17 different rates up to 1024 x 768. The ISS 408 supports 32 different output rates, up to 1365 x 1024 and including 480p, 720p, 1080p, and 1080i.

HDTV Video Formats – While both the ISS 108 and the ISS 408 offer eight inputs configurable for RGBHV, RGBS, RGsB, component video, S-video, and/or composite video, the ISS 408 also accepts HDTV.

ISS 108 & ISS 408 Scaled Output Rates

Resolution	50 Hz	56 Hz	60 Hz	75 Hz	85 Hz	AFL Mode (Lock at 50/60 Hz)
640 x 480	108, 408		108, 408	108, 408		108, 408
800 x 600	108, 408		108, 408	108, 408		108, 408
832 x 624			108, 408	108, 408		108, 408
848 x 480			108, 408			108, 408
852 x 480			108, 408			108, 408
1024 x 768	108, 408		108, 408	108, 408	108, 408	108, 408
1280 x 768		408 only				408 only
1280 x 1024	408 only		408 only			
1360 x 765			408 only			408 only
1365 x 1024			408 only			408 only
*720p			408 only			408 only
*1080p			408 only			408 only
*1080i			408 only			408 only

*HDTV @ 60 Hz only

APPLICATIONS for the ISS Series

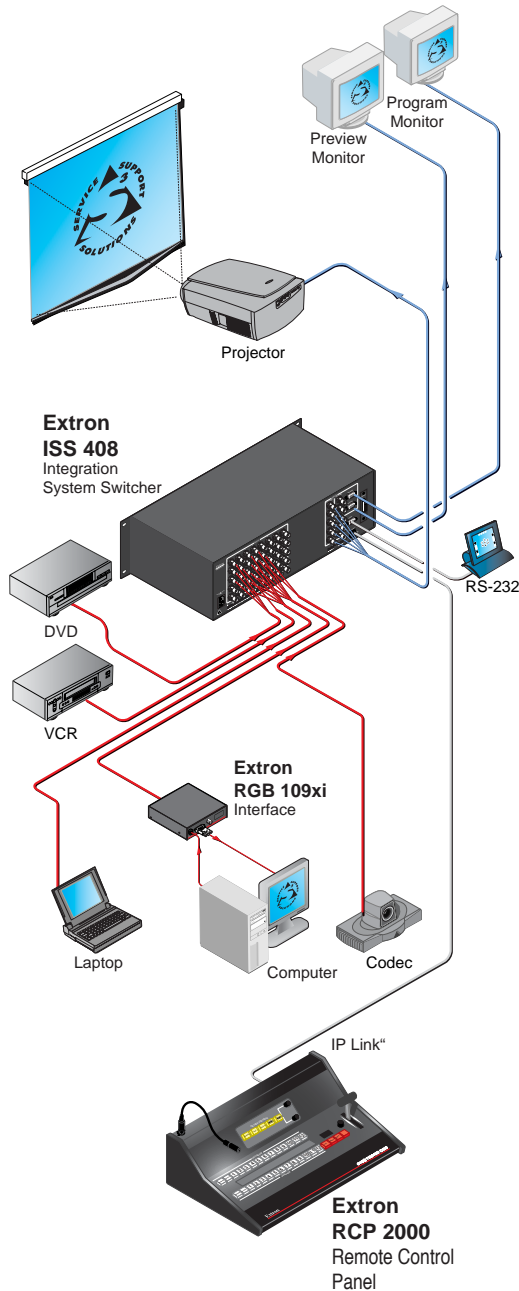

Boardroom and Conference Room

The ISS Series is a perfect tool for world-class boardrooms and conference rooms. A presenter can confidently control the presentation by reviewing sources on a local preview monitor before seamlessly switching them to the “program” output, which displays the image for the viewing audience. This can eliminate embarrassing surprises that can occur if you switch to the wrong input or section of a program.



Staging

In “live” environments, the ISS Series is the difference between a well-paced presentation and a well-intended but choppy presentation. Operators can switch sources with smooth “cut” and “dissolve” transitions, while a speaker can deliver an address without missing a beat.

Specifications

ISS 108 & ISS 408

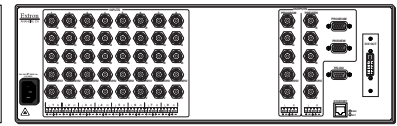
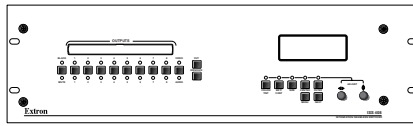

ISS 408 front and rear panel

VIDEO INPUT

Number/signal type	8 RGBHV, RGBS, RGsB, RGBcVs, component video, S-video, composite video
Connectors	8 x 5 female BNC
Nominal level	1V p-p for Y of component video and S-video, and for composite video 0.7V p-p for RGB 0.3V p-p for R-Y and B-Y of component video, and for C of S-video
Minimum/maximum levels	0V to 1.0V p-p with no offset
Impedance	75 ohms
Horizontal frequency	Autoscan 15 kHz to 120 kHz (RGB)
Vertical frequency	Autoscan 50 Hz to 100 Hz
Resolution range	Autoscan 720 x 525 to 1600 x 1200

VIDEO PROCESSING

Decoder	9 bit digital
Digital sampling	24 bit, 8 bits per color; 13.5 MHz standard (video), 140 MHz standard (RGB)
Colors	16.78 million
Horizontal filtering	4 levels
Vertical filtering	8 levels

VIDEO OUTPUT

Number/signal type	2 RGBHV, RGBS, scaled RGB
Connectors	2 x 5 BNC female, (2) 15-pin HD female
Nominal level	0.7V p-p for RGB
Minimum/maximum levels	0V to 0.7V p-p
Impedance	75 ohms
Scaled resolution	
ISS 108	640x480 ^{1,3,4,5} , 800x600 ^{1,3,4,5} , 832x624 ^{1,3,4,5} , 848x480 ³ , 852x480 ³ , 1024x768 ^{1,3,4,5}
ISS 408	640x480 ^{1,3,4,5} , 800x600 ^{1,3,4,5} , 832x624 ^{1,3,4,5} , 848x480 ³ , 852x480 ³ , 1024x768 ^{1,3,4,5} , 1280x768 ² , 1280x1024 ^{1,3,5} , 1360x765 ⁵ , 1365x1024 ^{3,5} , 720p ^{3,5} , 1080p ^{3,5} , 1080i ^{3,5}
	¹ = at 50 Hz ² = at 56 Hz ³ = at 60 Hz ⁴ = at 75 Hz
	⁵ = locked to the current input's vertical refresh rate
Return loss	-30dB @ 5 MHz
DC offset	±5mV maximum with input at 0 offset
Switching type	Seamless switching (cut or dissolve)

SYNC

Input type	Autodetect RGBHV, RGBS, RGsB
Output type	RGBHV, RGBS
Standards	NTSC 3.58, NTSC 4.43, PAL, SECAM
Input level	0V to 5.0V p-p
Output level	0V to 5.0V p-p
Input impedance	510 ohms
Output impedance	75 ohms
Max input voltage	5.0V p-p
Max. propagation delay	20 nS
Polarity	Positive or negative (selectable)

AUDIO

Gain	Unbalanced output: 0dB; balanced output: +6dB
Frequency response	20 Hz to 20 kHz, ±0.05dB
THD + Noise	0.03% @ 1 kHz at nominal level, 0dB gain
S/N	>90dB at rated maximum output drive (delete)
Crosstalk	<-80dB @ 1 kHz, fully loaded
Stereo channel separation	>90dB @ 1 kHz
CMRR	>75dB @ 20 Hz to 20 kHz

AUDIO INPUT

Number/signal type	8 stereo, balanced/unbalanced
Connectors	(8) 3.5 mm captive screw connectors, 5 pole
Impedance	>10 kohms unbalanced/balanced, DC coupled
Nominal level	+4dBu (1.23V), -10dBV (316mV)
Maximum level	+19.5dBu, (balanced or unbalanced) at 1%THD+N
Input gain adjustment	-15dB to +9dB, adjustable per input

AUDIO OUTPUT

Number/signal type	2 stereo, balanced/unbalanced
Connectors	(2) 3.5 mm captive screw connectors, 5 pole
Impedance	50 ohms unbalanced, 100 ohms balanced
Gain error	±0.1dB channel to channel
Maximum level (Hi-Z)	>+21dBu, balanced or unbalanced at stated %THD+N
Maximum level (600 ohm)	>+15dBm, balanced or unbalanced at stated %THD+N

NOTE: 0dBu = 0.775 volts (RMS).

CONTROL/REMOTE — SWITCHER

Serial control port	RS-232 or RS-422, 9-pin female D connector
Baud rate and protocol	9600, 8-bit, 1 stop bit, no parity
Serial control pin configurations	2 = TX, 3 = RX, 5 = GND
Ethernet control port	1 RJ-45 female connector
Ethernet data rate	10/100Base-T, half/full duplex with autodetect
Ethernet protocol	ARP, ICMP (ping), TCP/IP, Telnet
Program control	Extron's control program for Windows® Extron's Simple Instruction Set™ – SIS™ Microsoft Explorer, Netscape Navigator, Telnet

GENERAL

Power	100VAC to 240VAC, 50/60 Hz, 60 watts, internal, autoswitchable
Rack mount	Yes
Enclosure type	Metal
Enclosure dimensions	5.25" H x 17.5" W x 11.2" D (3U high, full rack width) 13.3 cm H x 44.5 cm W x 28.4 cm D (Depth excludes connectors and knobs. Width excludes rack ears.)
Product weight	11.2 lbs (5.1 kg)
Shipping weight	17 lbs (7.7 kg)
DIM weight	21
Listings	UL, CUL
Compliances	CE, FCC Class B

MODEL PART NUMBER

ISS 108	60-422-01
ISS 408	60-423-01
RCP 2000	60-571-01
DVI Option Board	70-244-01

Specifications are subject to change without notice.



Extron Electronics, USA
1230 South Lewis Street
Anaheim, CA 92805
800.633.9876 714.491.1500
FAX 714.491.1517

Extron Electronics, Europe
Beeldschermweg 6C
3821 AH Amersfoort, The Netherlands
+800.3987.6673 +31.33.453.4040
FAX +31.33.453.4050

Extron Electronics, Asia
135 Joo Seng Rd. #04-01
PM Industrial Bldg.
Singapore 368363
+65.6383.4400 FAX +65.6383.4664

Extron Electronics, Japan
Daisan DMJ Bldg. 6F, 3-9-1 Kudan Minami
Chiyoda-ku, Tokyo 102-0074
Japan
+81.3.3511.7655 FAX +81.3.3511.7656